

*Ecological Engineering to Reduce Rice Crop
Vulnerability to Planthopper Outbreaks*

**Interim Technical Report I: Visit to Jinhua, China
and Cai Be, Vietnam, July 2009.**

Geoff Gurr

Charles Sturt University, Australia.

ggurr@csu.edu.au

Introduction

Rice production in the tropics of Asia has a long history and billions of humans now depend upon this production system for their food staple. Rice eaters and growers form the bulk of the world's poor. Since the 'green revolution' of the 1970s, traditional production approaches have changed radically by the introduction of higher yielding varieties and higher inputs. Recent decades have witnessed a resurgence of insect pests, especially planthoppers. Dramatic yield losses have resulted as pest populations develop resistance to widely used insecticides and rice variety resistance breaks down. This broad phenomenon is dramatically evident in data from China where the rise in hybrid rice varieties has been accompanied by a dramatic increase in the area of land affected by the serious pest, white-backed planthopper. It is currently estimated that China loses about a million tons of rice paddy from planthopper outbreaks annually and in some years, like 2005, as much as 2.8M t.

As was recognised in the ACIAR-sponsored "scoping study to identify research and implementation issues related to management of the Brown Planthopper/virus problem in rice in Vietnam" (CP/2007/211), there is an urgent need to rethink the business of pest management in rice. One response to this was the International Rice Research Institute organised an international conference in June 2008 that brought together 88 scientists, agricultural directors and pesticide company representatives from Australia, Bangladesh, Cambodia, China, India, Indonesia, Japan, Korea, Laos, Malaysia, Philippines, Singapore, Taiwan, Thailand, USA and Vietnam as well as the FAO to discuss new approaches, new techniques and management tools. It is recognised that new strategies are required that are based on a better understanding of pest dynamics, ecologically-based methods for enhancing biological control and reducing the adverse impacts of indiscriminate insecticide use on natural enemies. To a large degree, these strategies already exist in the form of proven technologies used in other crop systems and/or deployed in rice in limited areas. This ecological engineering (Gurr et al. 2004) approach provides a framework to strengthen essential pest management ecosystem services that will improve crop health, thus preventing secondary pest outbreaks, like planthoppers.

The utilization of these principles for rice pests is now being explored with the assistance of Professor Geoff Gurr of Charles Sturt University (CSU) is a well-established research provider in the field of agricultural science and Professor Geoff Gurr's group is internationally acknowledged for work in integrated pest management, especially the use of ecological approaches to enhance biological control of pests. Prof Gurr is collaborating with the International Rice Research Institute (IRRI), initially undertaking *ad hoc* trips to the Philippines and China and now under the terms of a Letter of Agreement for the project

entitled *Ecological Engineering to Reduce Rice Crop Vulnerability to Planthopper Outbreaks*.

This interim technical report concerns the first trip undertaken by Prof Gurr under the terms of the Letter of Agreement, visiting ecological engineering research sites at Jinhua China and Cai Be, Vietnam and meeting with collaborating scientists.

Activities and Recommendations

Jinhua, China

Prof Gurr travelled to the ecological engineering research site located near Jinhua, Zhejiang Province, China on 16 July 2009 accompanied by Prof Lv Zhongxian from the Zhejiang Academy of Agricultural Sciences.

The research site was made up of an ecological engineering area (ca 37ha) on which a range of ecologically-based pest management strategies had been implemented, and a control area (ca 30 ha) on which conventional farmer practices were retained. The two areas were separated by a sealed roadway. Field sizes were small (typically ca 20 x 40m) an arrangement well suited to ecological engineering via field margin manipulation. At the time of the visit, early season rice was about to be harvested and replaced with a late season crop.

Local staff had implemented several field techniques for encouraging natural enemies. The first of these was extensive planting of flowering plants on the bunds. Some bunds were planted with soybean and casual observations in the district suggested that this was not an uncommon practice. Many bunds on the research site were also planted with sesame (*Sesamum indicum*) and this plant species was apparently not commonly used in the district though grown extensively in upland areas of the province. Sesame was just starting to flower at the time of the visit (Figure 1). The practical rationale for use of sesame was its agronomic compatibility with local conditions, and availability of inexpensive seed plus the fact that it could be harvested later in the season as a cash crop. From an ecological engineering perspective the presence of white flowers is encouraging because this colour is generally regarded as attractive to many parasitoids (eg Begum et al. 2006). It was locally considered a preferred foraging plant for honey bees. Other white flowering species shown to be valuable in ecological engineering systems developed in different crops include coriander (*Coriandrum sativum*), buckwheat (*Fagopyron esculentum*) and alyssum (*Lobularia maritima*) (Gurr et al. 2006). The fact that sesame

flowers in an indeterminate manner (ca 2 mo) will also provide nectar to natural enemies for an extended period of time. It would be valuable to experimentally test the effect of access to sesame flowers on a range of parasitoid species since the literature on ecological engineering does not appear to cover this plant.



Figure 1. Sesame planted on bunds surrounding rice fields on research site near Jin Hua, Zhejiang Province, China (16 July 2009, GM Gurr).

Forty light traps (Figure 1) had been installed on the ecological engineering site, this number being greater than that required for monitoring planthopper immigration. These may trap the pest in sufficient numbers to contribute towards pest suppression. There is, however a risk that natural enemies, particularly some hymenopteran parasitoids could be killed. Light trap contents should be checked for parasitoids species important for rice pest control. If these are present, number of light traps should be reduced to the minimum required for monitoring. The large numbers of light traps in the ecological engineering area could also attract – but not necessarily kill - pests from the nearby control area resulting in anomalous results. Consideration should be given to minimizing numbers of traps.

Some bunds were planted with wild rice, *Zizania* (unknown species) and Sudan grass (*Sorghum vulgare* var. *sudanense*) (Figure 2). *Zizania* this was said to be beneficial in

supporting non-pest planthopper (Fam: Tropicuchidae, unknown species) (Figure 3) that in turn were hosts of parasitoid species that also attached rice planthopper. This needs to be investigated to confirm the identity of the species and that it is not responsible for direct damage to rice or a vector of viral diseases. Sudan grass was said to be valuable as a trap crop for Lepidoptera pests. Stem borer (*Chilo suppressalis*) and leaf folder (*Cnaphalocrocis medinalis*) were the most important of these.



Figure 2. Wild rice planted on bunds surrounding rice fields on research site near Jinhua, Zhejiang Province, China (16 July 2009, GM Gurr).



Figure 3. Planthopper (Fam: Tropiduchidae, unknown species) on wild rice planted on bunds surrounding rice fields on research site near Jinhua, Zhejiang Province, China (16 July 2009, GM Gurr).



Figure 4. Roses (background) planted adjacent to rice on research site near Jinhua, Zhejiang Province, China (16 July 2009, GM Gurr).

Apart from bund manipulations, the presence of ornamental roses as a crop commonly grown in proximity to rice (Figure 4) may have value in providing nectar to natural enemies. Though the blooms are removed for sale some (lower quality ones) may be left on place (Figure 4). Roses also possess extra-floral nectarines that can provide nutrition to parasitoids irrespective of the availability of inflorescences.

On 17 July Profs Gurr and Lv met with staff of the Jinhua Plant Protection Station. A summary was provided of related research conducted by local staff in the lead up to the current work. This included use of soy and sesame intercropping, Sudan grass as a trap crop for stem borers, attract and kill lamps, sex pheromones for stem borers and leaf folder, resistance monitoring, pest resistance breeding in rice, insect taxonomy and use of ducks for pest control. Work was also underway looking at other possible flowering crop plants for use in ecological engineering. These included a white flowering plant, *Erigeron annuus* (Asteraceae). It was clear that much of this work had been of direct benefit in setting up so effectively the ecological engineering strategies on the research site.

A number of issues were raised in relation to the current field studies and the field sampling proposal (see Appendix 1). These issues were the extent of need for equipment and training to be provided to the Guilin site (Guangxi Province), how best to provide taxonomic services to the overall project, the merits of *directional* pitfall traps, changing the regularity of some sampling protocols to reduce labour requirements. The latter proposal was to use weekly internals for sweep net sampling, sticky traps, pitfall trapping whilst vacuum sampling, water pan trapping, sentinel plants were to be done on only four occasions each growing season. These would coincide with seedling, tillering, booting and milking stages of rice growth.

The local team also intended to conduct a spatial analysis of the landscape surrounding the research site. This would be based on a ground survey since only low resolution aerial images were available. There was general support for the need for equipment (eg traps and nets) to be standardised across all sites.

That evening, after travel back to Hangzhou, a working dinner was held during which Profs Gurr and Lv were able to discuss their trip with Zhejiang University collaborators Prof Cheng Jia An and Dr Zhu Zhen Rong. The major issue discussed was the merits of conducting additional experimentation on the ecological engineering areas. Prof Gurr cautioned against the use of experiments of the type that could compromise the integrity of the overall, two-treatment, and four site experiment being set up across China, Vietnam and Thailand. For example, an experiment testing the effects of spray vs. no-spray

treatments could lead to depleted natural enemy numbers in the wider ecological engineering area. In contrast, experiments that tested the relative merits of different candidate nectar plants, or that used dye of rubidium chloride to track natural enemy movement between crop and non-crop habitats, would be available and would not compromise the overall experiment.

Cai Be, Vietnam

On Sunday 19 July Prof Gurr travelled to Ho Chi Minh City accompanied by Prof Cheng of Zhejiang University. They were joined by Dr KL Heong, International Rice Research Institute, and commenced a trip to Cai Be the following morning. After a brief reception hosted by Mr Ho Van Chien at the Southern Plant Protection Centre Long Dinh, Tien Giang a field trip commenced to the ecological engineering research site (Figure 5). This comprised 36 farmer households covering an area of approximately 30ha. Though the area was made up of separately owned crops they appeared to be largely contiguous rather than being broken into discrete crops bounded by bunds. This clearly makes the likely value of bund vegetation management less likely to make a major impact on pest dynamics in the centre of areas sown to rice. Individual farmers were responsible for selecting their own rice varieties in the ecological engineering and nearby control area but no hybrid rice was being grown. Planting was synchronized in the region in line with the 'escape strategy' for reducing exposure to immigrant rice planthoppers. At the time of the visit, bunds had been sprayed with herbicide (Figure 6) in preparation for planting with nectar ground covers. A yellow flowered Asteraceae species (said to be *Vedalia striolata* but identity to be confirmed) was being propagated from stolons at the nearby university campus nursery. The basis for its selection was that it was easy to propagate, prostrate growth habit so could withstand trampling and had indeterminate flowering. Unlike the soybean and sesame used in Jinhua, China, it had no inherent value as a dual crop.

The rice crop was at an advanced stage of vegetative growth so an opportunity to measure the benefits of ecological engineering via bund groundcovers would have to wait until planting of the second crop in early November.



Figure 5. Ecological engineering research site, Cai Be, Vietnam (20 July 2009, GM Gurr).

DRAFT

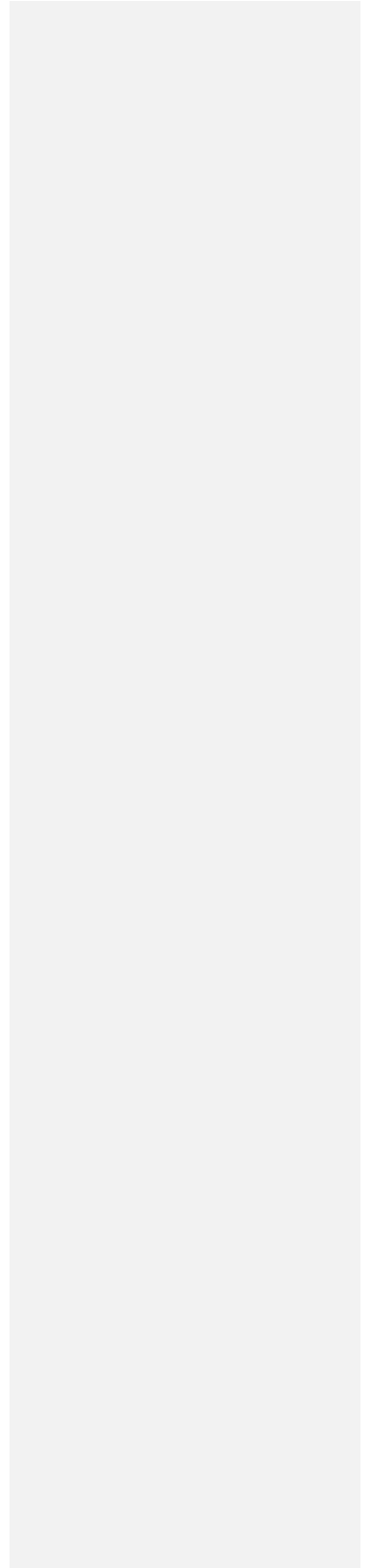



Figure 6. Herbicide-treated bund to be planted with groundcover species on ecological engineering research site, Cai Be, Vietnam (20 July 2009, GM Gurr).

On 21 July detailed discussions were held with staff at the Southern Plant Protection Centre to refine methods to be used in the project. It was decided to implement the scheduling proposed at the Jinhua meeting (see above). Further, water pan traps should be made from cheap take away food containers rather than proprietary bowls to minimize the risk of theft. The food containers should be sprayed with the paint detailed in Appendix 1. Other than covering the issues raised in earlier discussion at the meeting in Jinhua, a key aspect that was agreed upon was the use of 100% ethanol to preserve arthropod samples. This would maximize DNA quality, leaving open scope for molecular taxonomy to be undertaken at a later date. Plans were also outlined for a joint publication of a review article on the parasitoid fauna of rice pests. Dr Nan would be the Vietnamese contact person for this initiative. The vacuum sampler available to Vietnamese staff was inspected and measurements taken to allow Prof Gurr to check availability of similar devices in Australia for dispatch to Asian collaborators. Discussion extended to another possible

bund ground cover species, *Tridax procumbens* (Asteraceae), that was said to be yellow flowered and easy to propagate from seed. There was recognition that laboratory experiments were important to assess the benefit to key parasitoid species of access to such flowers and Prof Gurr agreed to make available to the 'Ricehoppers' site copies of key articles that gave detail of methods (eg Begum et al. 2006).

Conclusions

Several recommendations were made during the visit and the most important of these is that though the nature of ecological engineering methods being used on each site can vary to reflect local conditions it is critical for the overall integrity of the project that rigorous and CONSISTENT sampling and data capture methods are used on all sites. This will allow data from different sites in China, Vietnam and Thailand to be analyzed together. It is also important that on each site samples are taken in a manner that is consistent between the ecological engineering area and the control area.

Provided that the above imperatives are satisfied a number of subsidiary investigations can take place such as mark and recapture experiments to track movement.

References

Begum, M., Gurr G. M. & Wratten, S. D., Edberg, P. and Nicola H. I. (2006). Using selective food plants to maximize biological control of vineyard pests *Journal of Applied Ecology*, 43, 547-554.

Gurr G. M., Wratten, S. D. & Alfieri M. A. (eds). (2004). *Ecological Engineering: Advances in Habitat Manipulation for Arthropods*. CSIRO Publishing, Melbourne (Australasian publisher)/ CABI International, Wallingford (European Publisher)/ Cornell University Press, Ithaca (America's publisher). 244 pp. ISBN 0643090223.

Appendix 1: Amendments to working document suggested by GM Gurr 11 July 2009.

Sampling protocols for studying arthropod biodiversity-ecological engineering for rice pest suppression in irrigated tropical rice-ecosystem

Arthropod biodiversity may be studied through sampling, counting and identifying the specimens. Wherever identification to *named* species is not possible, individuals should be identified to 'morphospecies' (otherwise known as recognisable taxonomic unit). This means that specimens are sorted into categories in which all individuals are identical. For example 'Ichneumonid #1 or Coccinellid # 3). Specimens should be preserved to allow follow up identification. Scope for DNA barcoding is being investigated. Specimens can be pinned in the normal manner of preserved in 100 ethanol. Bulk, unsorted samples are best stored in a deep freeze until sorted. Scrupulous attention needs to be paid to labeling such bulk samples and individual specimens (eg, date collected, site, exact position or plot number if from within an experiment, collector's name are the minimum) to species. Several sampling techniques are to be used in the overall IIRI/ADB project may be used.

Formatted: Font: Italic

Insect sweep net

The use of sweep net is a simple and inexpensive way to monitor the presence of a variety of arthropods/insects in the ecosystem. If sampling effort is consistent (eg 20 sweeps or 30 seconds sweeping whilst walking slowly though vegetation) samples can also be used to infer relative abundance of arthropods within a vegetation type. The sweep net is ~~it is~~ a funnel-shaped net, which is made-up of a ~~cotton-muslin~~ nylon or similar synthetic fabric. It is important that the ~~The~~ net is mounted on a rigid metal ring rather than wire. This allows the net to be swept through dense vegetation, dislodging arthropods. The net's ring is attached to a long wood or metal- handled ~~wooden frame~~. A standard sweep net has a diameter of 28 cm with a length of 71 cm long. The stick handle is about 74 cm long.

Comment [g1]: Should we provide to collaborators a number of suitable nets to ensure comparability and quality?

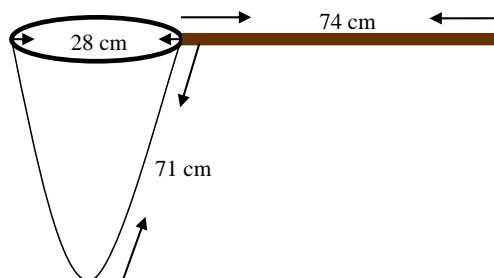

A typical sweep net

How to use a sweep net

1. Hold the sweep net near the end of the handle with the hoop end nearest to the ground in front of you.
2. Swing the net from side to side in a full 180° arc or forming a semicircle. Keep the circular frame of the open end of the net perpendicular to the ground and pointing to the direction of the swing.
3. Sweep one stroke per step as you casually walk through the field or down the row. Do not swing the net up and down.
4. In short vegetation, swing the net as deeply as possible.
5. In taller vegetation, sweep only deeply enough to keep upper edge of the sweep net opening even with the top of the plants.
6. The net should not go more than ~~10 inches~~ 25cm below the top of the plants during sampling.

Sampling arthropods by a sweep net

1. Sample arthropods ~~weekly or~~ once a week starting from the tillering stage (30 DAT) until the flagleaf stage (80 DAT) of the rice crop.
2. Sampling must be done at 10 am in the morning when all the morning dews have evaporated. Avoid sampling in wet weather.
3. Start to sweep from the end corner of the field towards???. Do twenty sweeps, which corresponds to one sample.
4. The second twenty sweeps going to the center of the field and the third twenty sweeps going to the other end corner of the field.
5. A total of sixty sweeps (three samples) along a diagonal pattern will be done in one-fourth hectare.
6. Swing the net as hard as possible after the last sweep. This will allow the insects to be deposited at the funnel end of the net.
7. Close the net by gripping the mid section by the palm.
8. Invert the net and put the collected insects in plastic bags and label with tags.
9. Transfer the collected insects in 3 labeled vials with 100% ~~70%~~ ethanol ~~alcohol~~.

Comment [g2]: We need to discuss the underlying research question. Is it simply what is the arthropod fauna in a given crop? If so a zig zag pattern in random parts of paddy is best. We might want to also ask the question what is the fauna in the crop at various distances from edge vegetation of different types.

Suggest pic be replaced or deleted as this is not proper sweep net technique – such arm's length posture is more typical of trying to catch a specific specimen.



Each passage of the net is considered one sweep.

The efficiency of a sweep net may vary depending on many factors. Different weather conditions, wind speed, air temperature, and intensity of solar radiation may affect the number of insects in the area while sweeping. Different habitats, especially the height of the plants, time of day, reflecting different cycles of behavior of the species, and different styles of sweeping are also factors to be considered.

Blower-vac machine

Blower-vac machine may be used for more quantitative studies of insects in rice. It is operated by a gasoline-powered motor. The machine sucks the insects from rice plants by vacuum pressure. This machine is similar to that described by Arida and Heong (1992). However, instead of a plastic bucket, it will use a modified enclosure made of metal.

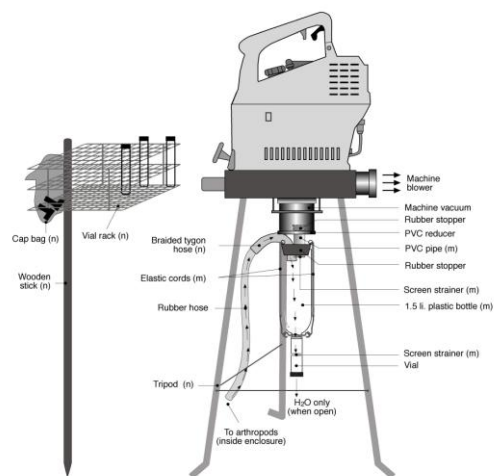

A modified blower-vac apparatus for sampling arthropods. Arrows indicate the flow of air, water and arthropods through the apparatus. Symbols: (n) new or (m) modified part from the original blower-vac apparatus.

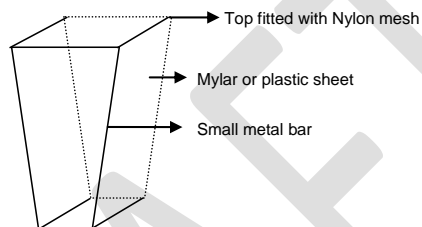

A modified enclosure made of metal (3 cm x 16 cm) and transparent mylar or plastic sheet (with 42 cm diameter top and 42 cm diameter bottom) with the bottom open and the top fitted with 1 meter nylon mesh cloth to prevent escape of moving arthropods.

Sampling of arthropods by blower-vac machine

1. Sample arthropods biweekly or every two weeks starting from the tillering stage (30 DAT) until the flagleaf stage (80 DAT) of the rice crop.
2. Biweekly sampling will consist of 10 Blower-Vac samples at every sampling date.
3. Sample arthropods from 10 randomly selected hills within the rice field.
4. To sample using the Blower-Vac, drop the enclosure over the rice plant to cover 1 hill.
5. Suck the arthropods from the nylon net sleeve, the air column, the plant surfaces and finally the water surface. The suction time will depend until all the insects are collected (suction time will later be prolonged as rice crop matures).
6. Place the collected insects in labeled vials with ~~70% alcohol~~ 100% ethanol.

Comment [g3]: Sounds fine but we should discuss the possibility of more sophisticated sampling (see comment on sweep net above).



A blower-vac machine in action in the field.

Comment [g4]: Will we provide the equipment? I think this is important.

Yellow pan trap

Many small day-active insects are attracted to the color yellow. Yellow pan traps collect insects that are attracted to the color. They are inexpensive and simple means of passively sampling insects in an area. This trapping method uses small pans filled with a mixture of water and liquid detergent. The pans are then placed on the ground in conspicuous places in the morning. When flying insects land on the surface of the water they rapidly sink and drown. At the end of the day or after 1-2 days, the water is strained through a fine sieve and the specimens are collected.

Option 1

1. Use 500 ml bowl. Deeper bowls experience less evaporation in hot climates.
2. Cut holes near top of bowl and cover with mesh. In excessive rain this allows water to flow out of the bowl without losing any samples.
3. Paint with yellow UV paint (e.g. Sparvar Leuchtfarbe, Spray-Color GmbH, Merzenich, Germany or <http://www.guerrapaint.com/tandc.html> USA).
4. Place bowls at approximately the same height of vegetation (50-100 cm) using a wire frame.
5. Add a mixture of 400 ml water and sodium benzoate preservative.
6. Place the first bowl in the vegetation bordering the crop/ on the bund at field edge and the others in a transect or and at distances of 0, then at 1 m, 2 m, 4m, 8m, 16m, etc into the centre of the paddy.
7. Cover each bowl with a coarse wire mesh to prevent scavenging of insects by birds.
8. Leave out for 48 hrs at a time.
9. Repeat a minimum of 6 times throughout the rice-growing season.
10. Use an aquarium net or fine sieve to collect the insects and place in 100>90% ethanol.

Comment [g5]: Can we provide the painted bowls?

Comment [g6]: Add concentration as per my earlier email



Yellow pan traps at flowering stage of the rice crop.

Option 2.

1. Use yellow pans.
2. Cut holes near top of pan and cover with nylon mesh.
3. Support the bowls with wire and wooden stick.
4. Add a mixture of water and salt and oil or a mixture of water and picric acid.
5. Place the yellow pan just below the canopy of the rice plants supported by a wire frame and wooden stick.
6. Set-up the yellow pan traps on the bunds and inside the rice field 5 meters apart from each other at 21 DAT, 45DAT, and 65 DAT, and 85 DAT (seedling stage, vegetative stage, flowering or reproductive stage, and ripening stages).
7. Collect the pans after 24 hours.
8. Collect the insects by a fine sieve net and place in ~~70% alcohol~~ 100% ethanol.

Add info from above re transect

Comment [g7]: Add concentrations

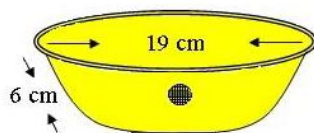

Yellow pan



Yellow pan trap at vegetative stage of the rice crop.

Pitfall trap

Pitfall traps are often used to sample crawling or ground-dwelling insects. They are placed below the ground with the rim of the container below the surface of the soil. Detergent may be added to reduce the surface tension allowing insects to sink into the liquid.

Sampling by pitfall traps

1. Install the pitfall traps two to three times a week before dibble and at seedling stage until harvest time.
2. Dig holes with the same size as the traps.
3. Dig holes every 5 meters within the bunds and at the center of the field forming a straight line.
4. Make sure the rim of the trap is just below the surface of the soil.
5. Put some mixture of water and teepol on the trap. Ten percent picric acid can also be mixed with water to preserve the insects.
6. To keep rainwater out of these traps, a cover or a mylar roof supported by a metal wire can be placed above the opening of the trap.
7. Leave the traps for 1 day.
8. Retrieve the traps after 1 day.
9. To empty the traps, take the inside cup and turn it over in a labeled plastic bag.
10. Transfer the collected insects in labeled vials with ~~70% alcohol~~ 100% ethanol.

11. Add info from above re transect

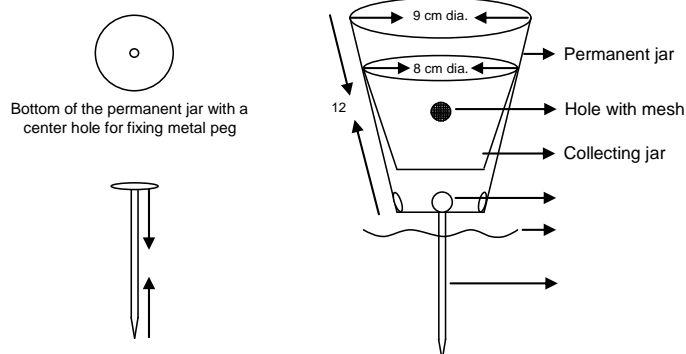

Plastic containers for pitfall trap

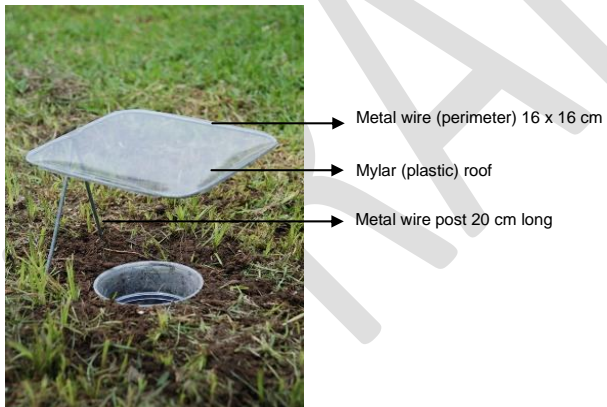

Pitfall trap with a mylar roof and plastic container below the ground

Light traps

Light traps are simple methods for collecting large numbers of insects attracted to light. At the bottom is a collecting pan with alcohol or a mixture of water and detergent.

Sampling by light traps

1. Install a single fluorescent bulb light trap 250 m away from the field.
2. Traps should run once a week between dusk and dawn.
3. Collect the insects at 7am in the morning.
4. Transfer the insects in labeled vials with ~~70% alcohol~~ 100% ethanol.



A dry fluorescent light trap

Bait traps for egg parasitization

1. Use 30-day-old rice plants.
2. Thin the rice plants to 5 tillers each pot.
3. Introduce five gravid female adults to the rice plants for oviposition.
4. Remove the adults after 24 hours.
5. **Bring the plants with newly laid eggs to the rice field and expose for 48 hours.**
6. Retrieve the rice plants with eggs after 48 hours and bring to the greenhouse or laboratory.
7. Remove the tillers with eggs and transfer to petri dishes lined with moistened filter paper.
8. Check daily for parasitoids emergence.

Comment [g8]: Fine but again we need to discuss underlying question and the resultant layout/design to be used.



Rice plants with eggs ready for field exposition



A wooden stick is pegged on the bait trap in the field
Identification of arthropod samples from all sampling techniques

1. Place the collected samples in labeled vials with 70% ethyl alcohol.
2. Sort, count and identify the collected arthropods to species level (if possible).
3. Group the sampled arthropods based on guilds (predators/omnivores and parasitoids/parasites) described by Moran and Southwood (1982).

Data analysis

1. The raw data will be entered into Excel file.
2. Analysis will follow.

References:

Arida GS, Heong KL. 1992. Blower-Vac: a new suction apparatus for sampling rice arthropods. *International Rice Research Newsletter* 17(6):30-31.

Barrion AT. Personal communication.

Moran VC, Southwood TRE. 1982. The guild composition of arthropod communities in trees. *J. Animal Ecol.* 51:289-306.